

NOTES:

1 Refer to Secondary Sheet for Tabulated Data.

2 $\phi A1$ and $\phi A2$ shafts may near butt except:

When any Bore $> \phi .313$ the component shaft MAX penetration is .200 or when both Bores $> \phi .313$ the component shaft MAX penetration is .200 & the MIN shaft end to shaft end is .475

3 Hubs and HELI-CAL FLEXURE are made from a single piece of material.

4 Set Screw attachment, hex. socket, cup point set screw furnished: both hubs.

5 Backlash: None. No lubrication required.

6 Permitted axial motion from free length: ± 0.10 .

7 RPM: Up to 10,000, depending on application.

8 Working torque ratings are based upon continuous duty with noted misalignments applied separately and may be increased with improved alignment. See Tabulated Sheet

9 Permissible shaft misalignment: Angular, up to 5 degrees. Offset, up to 0.10 (FIM, 0.20)

10 Weight based on AR087-8mm-6mm

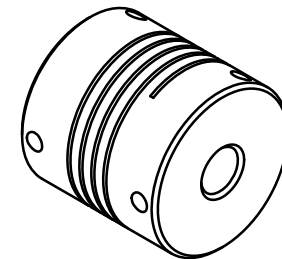
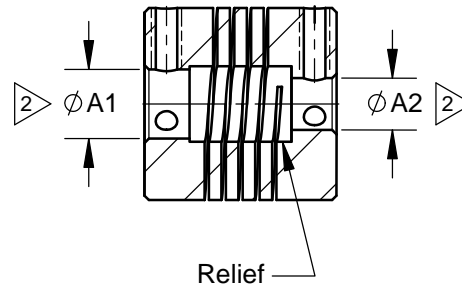
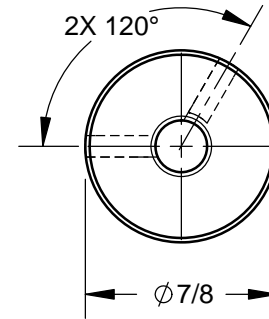
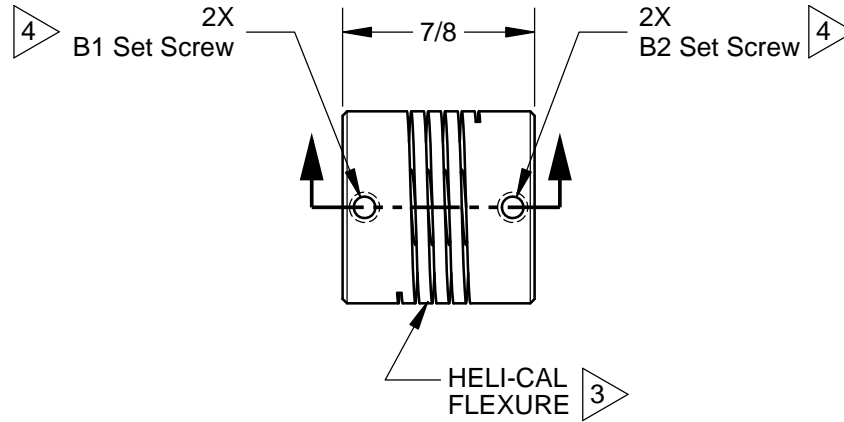

NOTICE: THE INFORMATION AND DATA CONTAINED HEREIN IS CONSIDERED PROPRIETARY TO HELICAL PRODUCTS COMPANY, INC., AND SHALL REMAIN THE EXCLUSIVE PROPERTY OF HELICAL. THE HOLDER WILL ASSUME CUSTODY AND CONTROL THAT THIS DOCUMENT WILL NOT BE COPIED, REPRODUCED OR DISCLOSED WITHOUT THE EXPRESS WRITTEN CONSENT OF HELICAL. POSSESSION OF THIS DOCUMENT DOES NOT CONSTITUTE A GRANT TO MANUFACTURE ANY ITEM. Copyright HELICAL PRODUCTS CO. INC.

12-2-14	---	ECR#14102000 added calc. weight	DCE	EK
08-01-13	---	Redrawn in Solidworks	CL	JAJ/EK
12-18-09	---	Finish was Chromic Acid Anodize; Updated GD&T	JAJ	HG
08-10-98	---	Clerical Format Update/ No Revision	BJM	MC
DATE	LTR	REVISION	APVR	

Unless otherwise specified all tolerances and dimensions are in inches.

Inch	Metric
X/XX \pm 1/64	X \pm 0.5mm
.XX \pm .01	X.X \pm 0.25mm
.XXX \pm .005	X.XX \pm 0.15mm

Angles $\pm 2^\circ$

Break sharp corners .010 MAX
All surface finish 63 roughness
Do Not Scale Drawing

		901 West McCoy Lane P.O. BOX 1069 SANTA MARIA, CA. 93456 U.S.A. PHONE (805) 928-3851 FSC13201	
		DRAWN BY MM	DATE 11-27-79
CHECKED BY MC	DATE 11-27-79	MATL 7075-T6 Aluminum Alloy	FINISH Anodize IAW HPS1000
APPRVD BY APA	DATE 11-27-79	WEIGHT (calculated) 18.5 g	DRAWING NUMBER AR087
SHEET 1 of 3		REV	REV

TABULATED DATA

UOS all dimensions are in inches.
Copyright HELICAL PRODUCTS CO INC

MATERIAL: 7075-T6 Aluminum Alloy

FINISH: Anodize IAW HPS1000

Drawing Number

AR087

REV

DO NOT SCALE DRAWING

SHT 2 of 3

ITEM DESCRIPTION (Part Number)	BORE SIZES		SET SCREW		TORQUES (lbin)		
	TOLERANCE +0.002in or +0.05mm -0.000in or 0		B1	B2	Momentary	Non-Reversing	Shock or Reversing
Ø A1	Ø A2						
AR087-4-4	.125in	.125in	#4-40	#4-40	32	16	8
AR087-5-4M	.157in	.120in	#6-32	#2-56	32	16	8
AR087-6-6	.188in	.188in	#6-32	#6-32	32	16	8
AR087-5mm-6	5.00mm	.188in	#6-32	#6-32	32	16	8
AR087-6mm-6	6.00mm	.188in	#6-32	#6-32	30	15	8
AR087-8-4M	.250in	.120in	#6-32	#2-56	30	15	7
AR087-8-4	.250in	.125in	#6-32	#4-40	30	15	7
AR087-8-3.82mm	.250in	3.82mm	#6-32	#4-40	30	15	7
AR087-8-5	.250in	.157in	#6-32	#6-32	30	15	7
AR087-8-6	.250in	.188in	#6-32	#6-32	30	15	7
AR087-8-5mm	.250in	5.00mm	#6-32	#6-32	30	15	7
AR087-8-6mm	.250in	6.00mm	#6-32	#6-32	30	15	7
AR087-8-8	.250in	.250in	#6-32	#6-32	30	15	7
AR087-10-3	.313in	.094in	#6-32	#2-56	28	14	7
AR087-10-4M	.313in	.120in	#6-32	#2-56	28	14	7
AR087-10-4	.313in	.125in	#6-32	#4-40	28	14	7
AR087-10-5	.313in	.157in	#6-32	#6-32	28	14	7
AR087-10-6	.313in	.188in	#6-32	#6-32	28	14	7
AR087-10-6mm	.313in	6.00mm	#6-32	#6-32	28	14	7
AR087-10-8	.313in	.250in	#6-32	#6-32	28	14	7
AR087-10-7.5mm	.313in	7.50mm	#6-32	#6-32	28	14	7
AR087-10-10	.313in	.313in	#6-32	#6-32	28	14	7
AR087-12-4	.375in	.125in	#6-32	#4-40	28	14	7
AR087-12-4mm	.375in	4.00mm	#6-32	#6-32	28	14	7
AR087-12-6	.375in	.188in	#6-32	#6-32	28	14	7
AR087-12-5mm	.375in	5.00mm	#6-32	#6-32	28	14	7
AR087-12-6mm	.375in	6.00mm	#6-32	#6-32	28	14	7
AR087-12-8	.375in	.250in	#6-32	#6-32	28	14	7
AR087-12-10	.375in	.313in	#6-32	#6-32	28	14	7
AR087-12-8mm	.375in	8.00mm	#6-32	#6-32	28	14	7
AR087-12-12	.375in	.375in	#6-32	#6-32	28	14	7

TABULATED DATA

UOS all dimensions are in inches.
Copyright HELICAL PRODUCTS CO INC

MATERIAL: 7075-T6 Aluminum Alloy

FINISH: Anodize IAW HPS1000

Drawing Number

AR087

REV

DO NOT SCALE DRAWING

SHT 3 of 3

ITEM DESCRIPTION (Part Number)	BORE SIZES		SET SCREW		TORQUES (lbin)		
	TOLERANCE +0.002in or +0.05mm -0.000in or 0		B1	B2	Momentary	Non-Reversing	Shock or Reversing
	Ø A1	Ø A2					
AR087-10mm-5mm	10.00mm	5.00mm	#6-32	#6-32	28	14	7
AR087-16-4M	.500in	.120in	#6-32	#2-56	28	14	7
AR087-16-6	.500in	.188in	#6-32	#6-32	28	14	7
AR087-16-5mm	.500in	5.00mm	#6-32	#6-32	28	14	7
AR087-19-12	.594in	.375in	#6-32	#6-32	28	14	7
AR087-20-12	.625in	.375in	#6-32	#6-32	28	14	7
AR087-20-20	.625in	.625in	#6-32	#6-32	28	14	7