

**Flexible Couplings  
Machined Springs  
U-Joints**

---



**Helical Products**



Innovative Solutions for  
Mechanical Motion Control

Visit [heli-cal.com](http://heli-cal.com)

**Download CAD drawings**



## Contents

### THE HELI-CAL FLEXURE

Now You Can Dream .....	3
The HELI-CAL Flexure Problem Solver .....	4
Design Benefits of the Flexure .....	6
Operating Characteristics .....	6

### HELI-CAL FLEXURE FLEXIBLE COUPLINGS

HELI-CAL Flexure, Basic Product Summary .....	9
W Series, Aluminum and Stainless Steel .....	10
DS Series, Aluminum .....	12
MC Series, Aluminum and Stainless Steel .....	14
A Series, Aluminum .....	16
H Series, Stainless Steel .....	16
Available Bore Diameters .....	18

### IDEA STIMULATORS

X-Series Radial Slot Coupling .....	21
A New Angle on Universal Joints .....	22
Flexure Attachments that Make Sense .....	23
What is a Machined Spring? .....	24

### PLUS

Engineering Proposal Form .....	25
Top Industries Served .....	26

<https://www.mwcomponents.com/uploads/HPC-Supplier-Quality-Assurance-Purchase-Order-Clauses.pdf>

#### Helical Products,

AS9100/ISO9001 Certified, RoHS & ITAR Compliant  
901 W. McCoy Lane  
Santa Maria, CA 93455 USA

## Often imitated, never duplicated.

HELI-CAL® Flexure, flexible couplings are machined from single piece, homogenous high-strength materials into helical (curved beam) configurations which eliminate elastomeric elements like rubber bushings, spiders, rubber discs and pads. Helical couplings compensate for shaft misalignment and work at high speed, transmitting high torque at a constant velocity. There is zero backlash. No maintenance is needed.

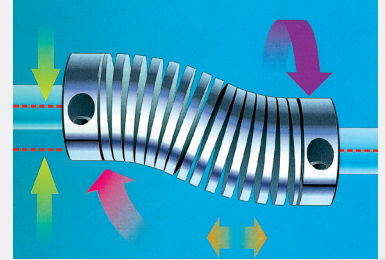

These couplings provide dynamic stability and vibration-free, smooth bearing loads, even at misaligned positions. The couplings find applications in flight controls, instrumentation, sensors, encoders, resolvers, lead screws, ball screws, air cooling units, pumps, fans, machine tools, CNC machines, duplicators, drones, wind and wave power generators, 3D printing and anywhere there is a need for motion control.

## Six reasons to choose HELI-CAL

- 01 State-of-the-art, single piece, flexible (and torsionally stiff) couplings, utilizing the HELI-CAL Flexure.**  
No maintenance, no backlash, no lubrication, constant velocity, and smooth bearing loads.
- 02 Engineering collaboration**  
Technical consultation for performance and stress calculations, designs including custom drawings, and 3D CAD models
- 03 Quality product**  
Over 65 years experience in perfecting manufacturing machinery and procedures used to produce HELI-CAL Flexure couplings that are of consistent high quality.
- 04 On-Time-Delivery (OTD)**  
Our ERP and production monitoring systems enable us to achieve consistently high OTD.
- 05 Originator of HELI-CAL Flexure couplings**  
Over 11,000 successful coupling designs; over 30,000 customers served.
- 06 Custom/Complex Couplings**  
In addition to a full line of standard couplings, the HELI-CAL Flexure can accommodate a variety of design requirements, such as specialized custom end attachments like tangs, flats, slots, pinholes, clamps, grooves, flanges, bolt circles, castellations, or threaded ends.

Contact us: [heli-cal.com](http://heli-cal.com) or email [sales@heli-cal.com](mailto:sales@heli-cal.com)

# The HELI-CAL® Flexure

## Unlimited Design Versatility...

The inspiration for the HELI-CAL Flexure, the cylindrical helix ingredient for our basic product lines, came from the observation that one-piece, “flexured” flexible couplings offered maximum versatility in terms of form, function and reliability.

Over time, the adaptability of the HELI-CAL Flexure has helped to solve thousands of mechanical misalignment and motion control problems.

The unique, mechanical characteristics of the “Flexure” have enabled Helical Products to develop a series of highly versatile, “flexured” products which can compensate for irregularities such as angular and skewed misalignment, parallel offset and axial motion. All of this can be accomplished while maintaining constant rotational velocity and smooth bearing loads.

### Here’s the HELI-CAL Flexure...



...as a flexible coupling

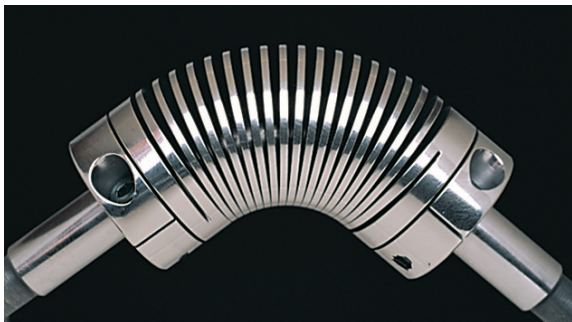

...as a U-joint



...as a machined spring



The HELI-CAL Flexure is a flexible helix (curved beam) machined from one piece of material into a specific configuration that incorporates special design requirements, performance features and/or characteristics.

Helical’s product lines today include flexible couplings, u-joints, and custom machined springs.

The following pages present the many advantages of HELICAL Flexure technology. The charts, data and information are based on our “standard” series of one-piece, flexible couplings, which are usable for a multitude of applications. As you become acquainted with the Flexure, you will see how versatile it can be. You will see also how the HELI-CAL Flexure can have a positive and marked impact on system performance, production efficiencies and overall cost savings.

### If you do not see it here, just contact us.

Our product design engineers can design, develop and produce a custom HELI-CAL Flexure to meet your specific requirements.

## Coil Width



By varying the thickness of the coils, a Flexure can accommodate increasing amounts of torque and radial loads. The designer may specify torsional stiffness and compression spring rates independent of other factors.

### Realizing Engineering Objectives with Design Solutions:

#### The HELI-CAL Flexure Problem Solver

##### Freedom of design... for maximum versatility

The coupling's hallmark is flexibility in form and function. Designed from the start with your goals in mind and manufactured to exacting specifications, the HELI-CAL Flexure offers many problem-solving, performance-enhancing features.

##### Coil configuration

The individual performance capability of each Flexure is determined by: coil width, inside diameter, number of coils, number of starts and material. Altering any one of these factors changes the performance characteristics of the "Flexure."

For example, the HELI-CAL Flexures illustrated display identical outside diameters and lengths. The effects of their variable characteristics—such as coil width, inside diameter, number of coils and starts are explained in the adjacent pictures.

##### Coil widths and inside diameters

As the coil width or inside diameter are changed such aspects as torque...angular misalignment (bending moment)... parallel offset (radial load)... torsional stiffness... and compression spring rate, are altered.

## Inside Diameter



When the inside diameter changes, so does the torque capacity, torsional stiffness and axial spring rates, without restricting your choice of bore sizes.

##### Number of coils

As the number of coils is changed, all of the characteristics except the torque capacity are affected.

##### Number of coil starts

- 01 A single start design has one continuous coil.
- 02 A double start has a second coil starting 180 degrees from the first.
- 03 A triple start has three interwound coils, each spaced 120 degrees apart.

When a multi-start helix is used (double or triple), the effect is to increase the torque capacity and torsional stiffness while reducing misalignment capabilities (angular and parallel).

##### Material

The proper material used in the manufacture of any HELI-CAL Flexure affects much more than just torque capacity. Factors such as elasticity, fatigue, corrosion resistance, mass, magnetic permeability, operating temperature, availability and cost also play important roles. High strength materials such as 17-4PH CRES\*, 15-5 PH, C300 Maraging Steels, BETA C Titanium, MP35N, 4340/4340M, 300 Series Stainless, and 7075-T6 Aluminum, are just a few of the common choices for meeting design and performance needs. Non-metallic materials are also available such as engineered plastics like Delrin™ 150, and glass impregnated epoxies like Ultem 2300.

\*CRES - Corrosion resistant steel

## Number of Coils



When the number of coils is changed the torque capability remains unaffected. All of the other characteristics change.

### Attachments

In addition to being able to alter the characteristics of the HELI-CAL Flexure, you may have your attachment method integrated into the final product.

#### Typical attachment options might include:

- integral clamps
- set screws
- set screw at one end and an integral clamp at the other
- pins
- slotted hubs
- flanges
- gears
- removable caps
- threaded bores with a wrench flat
- or...whatever your design requires

## Number of Coil Starts



Multiple, (typically two) helical beams provide high torsional stiffness. (Shown: single, double and triple start.)

### Bore variety

They may be engineered to include a variety of bore configurations. These variations include round, threaded, single or double-D, spline, keyway, tapered and other unlimited options.

The HELI-CAL Flexure or flexible coil section of the coupling can be custom designed and manufactured to your specifications. Whether your considerations include high torque, angular or parallel misalignment, critical torsional stiffness, precise compression spring rates, or special end connections, it is likely that the HELI-CAL Flexure will meet or exceed your particular design requirements.



## More than a coupling

The HELI-CAL Flexure concept brings broad design flexibility to your applications. Depending on your needs, the Flexure can serve as a flexible shaft coupling, universal joint, spring clutch, machined spring or your own unique specialized component.

## Adaptability

The Flexure's ability to accommodate various performance characteristics and Helical's ability to integrate attachments directly enhances your freedom to design.

## One-piece integrity

Not only does the Flexure integrate multiple functions and parts into a single compact unit without moving parts, backlast, or maintenance. It can incorporate complex attachments.

## State-of-the-art

High quality performance is achieved with magnetic or non-magnetic corrosion-resistant stainless steel, as well as aluminum alloys. Flexures are also successfully manufactured using various materials such as Delrin™ and titanium.

# Operating Characteristics

## Misalignment compensation

The flexing capacity of the HELI-CAL Flexure can compensate for a variety of misalignments, including parallel, angular and skewed (three-dimensional) misalignment.

## Angular

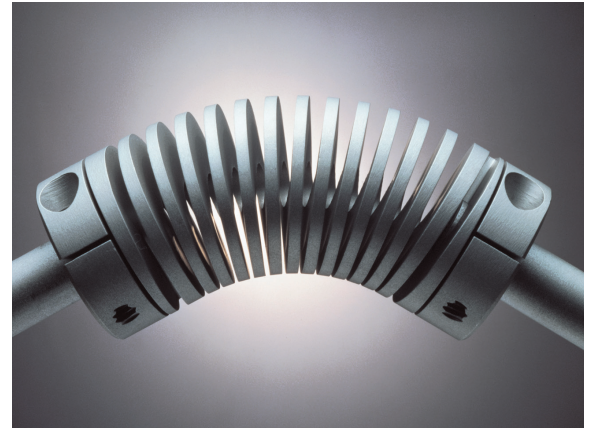

Angular misalignment is the easiest form of misalignment for most couplings to accept, and thus one of the most practical applications of a flexible coupling. Allowing only enough space between coils to partially close the gap during bending, the HELI-CAL Flexure can accept an angular misalignment of 20 degrees or more (and even up to 90 degrees in special u-joint applications).

## Optimized torque capacity

The basic requirement of a flexible coupling is to transmit torque loads without permanent distortion or damage and without imposing undue bending or radial loads upon the driver or driven components. Once the working torque rating of a HELI-CAL Flexure coupling is established—based on misalignment and design criteria, material specifications and service factors supplied during the design process—its operational life is virtually unlimited.

## Configurable torsional stiffness

Every flexible shaft coupling has some torsional flexibility. Torsional flexibility reflects the amount of twist in a system; torsional stiffness the degree of resistance against twist. The HELI-CAL Flexure can be configured (with thicker coils, for example), to provide the exact amount of torsional flexibility required in an application.

## Parallel



Parallel misalignment is the most difficult form of misalignment for couplings to compensate for. It can also be the most damaging to shafts, bearings and motors. The HELI-CAL Flexure, through lateral displacement, transforms an application's parallel misalignment problems into angular displacement within the coupling. The center coils of the HELI-CAL Flexure can become an intermediate shaft that can allow 10, 20 or 30 thousandths of an inch of parallel offset or more.

### Smooth bearing loads

Bearing loads are primarily generated by a coupling's natural resistance to bending, and can be very destructive forces to an apparatus and its rotational components. The HELI-CAL Flexure maintains a very constant radial and bending load at all points of rotation, providing exceptionally uniform bearing loads.

### Constant velocity

In a rotating system, constant velocity refers to the relative rotational speed of the input and output shafts. In a constant velocity system the driven end of the coupling turns exactly the same rate as the driver end. When operating under a uniform load the HELI-CAL Flexure design provides constant velocity and alleviates the following:

## Skewed



When shafts are not in the same plane (skewed), the HELI-CAL Flexure's abilities to compensate are the same as with either parallel or angular misalignment - but in the third dimension. A Flexure designed with more coils in a series can compensate for as much three-dimensional misalignment as your application requires.

- **Backlash.** The HELI-CAL Flexure has zero backlash, because of its one-piece construction.
- **Angular misalignment,** which can induce large fluctuations in rotational velocity in many coupling designs, is corrected by the HELI-CAL Flexure's constant spring rate at all points of rotation.
- **Torsional variations,** which can induce differences in hub-to-hub velocity when subjected to dynamic loading, are minimal in steady-state applications of the HELI-CAL Flexure.
- **Concentricity.** When there is a lack of it— particularly in the case of couplings with backlash or where production variation is difficult to prevent—the HELI-CAL Flexure's one-piece integrity minimizes sinusoidal variations.

Continued



This sampling of “standard” HELI-CAL Flexure couplings and specialized u-joints illustrates the variety of materials, coil configurations, bore diameters and attachment methods available to you.

No matter what its size or shape, the HELI-CAL Flexure design assures performance, reliability, quality and versatility, arguably unmatched in the coupling industry.

## Adaptable Operating Speeds

The ability to adapt to high— and low—speed applications is another inherent benefit of the HELI-CAL Flexure’s design. The Flexure transmits motion throughout its length and cross section in a continuous helix from end to end. Torsional loading tends to make the HELI-CAL Flexure draw toward its centerline, reducing the chance of whipping action normally associated with rotating components. Consequently, vibrations are kept to a minimum at all rotating points.

## Axial Compensation

Axial movement is inherent in any rotating componentry, such as the rotor assembly in a motor. Through compression/extension, the HELI-CAL Flexure absorbs and compensates for axial movement or end play. The curved-beam structure of the HELI-CAL Flexure operates naturally in this axial compensation mode, and special designs can accommodate for even large displacement applications.

## HELI-CAL Flexure, Basic Product Summary

Refer to the summary chart on the next page to get an idea as to which coupling series most closely fits your application needs. You’ll then be able to find the appropriate coupling by following the series column down to the page number. If you do not see the coupling you need in this catalog, let us know. Our engineers can create custom Flexure designs to meet your specific performance demands.







The charts on the following pages highlight features and technical data for each of the standard HELI-CAL coupling series.

## Information covered by each chart includes

- Dimensional data
- Performance data
- Special notes
- Ordering information



# HELI-CAL® Flexure, Basic Product Summary

W Series		DS Series	MC Series		A Series	H Series
aluminum 7075-T6	stainless steel 17-4PH	aluminum 7075-T6	aluminum 7075-T6	stainless steel 17-4PH	aluminum 7075-T6	stainless steel 17-4PH
						
Description						
General purpose, light to medium duty. An economical, maintenance free coupling with metric dimensions, used in a variety of applications.	Stainless steel version of the “WA(C)” series, with higher torque capacity and torsional stiffness. Increased fatigue resistance with metric dimensions and fasteners.	Low inertia, high performance, aluminum coupling, using Helical double start technology. Torsionally stiffer and higher torque capacity than the “A” series. Lighter with lower inertia than the “H” series.	A general purpose aluminum coupling, used where more parallel misalignment is required. Has a large range of shaft sizes, with optional keyways.	Stainless steel version of “MCA(C)” series, with higher torque capacity and torsional stiffness. Increased fatigue resistance.	General purpose, light to medium duty. An economical, maintenance free coupling, used in a variety of applications.	Stainless steel version of “A” series, with higher torque capacity and torsional stiffness. Increased fatigue resistance.
Typical Applications						
Used for encoder/resolver applications, low torque pump, lead screw and various other applications.	For situations requiring a heavy duty coupling, for pump, lead screws, and positioning systems. Also for process equipment in industrial situations. Anywhere a rugged, tough, long-lasting coupling is needed.	For high-speed motion control systems, where fast response time is important. E.g., lead and ball screws, encoders/resolvers, and anywhere high torsional stiffness is required.	Good for encoder/resolver applications, moderate torque pump, lead screw, and various other applications.	Good for pump, conveyor systems, and industrial processing equipment, where absolute reliability is required. Anywhere a rugged, tough, long-lasting coupling is needed.	Used for encoder/resolver applications, low torque pump, lead screw and various other applications.	For situations requiring a heavy duty coupling such as pumps, lead screws, and positioning systems; also for process equipment in industrial situations. Anywhere a rugged, tough, long-lasting coupling is needed.
Misalignment compensation						
5° angular, .25mm parallel offset, .25mm axial motion	5° angular, .25mm parallel offset, .25mm axial motion	3° angular, .010 inch parallel offset, .008 inch axial motion	5° angular, .030 inch parallel offset, .010 inch axial motion	5° angular, .030 inch parallel offset, .010 inch axial motion	5° angular, .010 inch parallel offset, .010 inch axial motion	5° angular, .010 inch parallel offset, .010 inch axial motion
Torque range						
.59-20 Nm	1.2-39 Nm	12-234 lb/in	20-286 lb/in	40-556 lb/in	1.2-51 lb/in	2.4-100 lb/in
Standard bore diameters* (inch and/or metric bores available)						
0.118-0.787 inch 3mm-20mm	0.118-0.787 inch 3mm-20mm	0.188-0.750 inch 4.78-19.05mm	0.250-.875 inch 6.35-22.23mm	0.250-1.000 inch 6.35-25.40mm	0.059-0.750 inch 1.5-19.05mm	0.059-0.750 inch 1.5-19.05mm
Attachment						
Clamp or set screw	Clamp or set screw	Clamp	Clamp or set screw Keyways optional	Clamp or set screw Keyways optional	Clamp or set screw	Clamp or set screw
Operating temperatures						
Up to 100°C	Up to 300°C	Up to 200°F	Up to 200°F	Up to 600°F	Up to 200°F	Up to 600°F
Speed (in wind-up direction)						
10,000 rpm	10,000 rpm	10,000 rpm	3,600 rpm	3,600 rpm	10,000 rpm	10,000 rpm
For more information, see page						
10	10	12	14	14	16	16

Note: For PF Series see page 20.

\*Refer to pages 18-19 for other available bore diameters.

## Features

- Metric dimensions and fasteners
- Metric and/or inch bores available
- Available in 7075-T6 aluminum alloy or 17-4 PH corrosion-resistant steel
- General purpose

The W Series combines the best features of the A Series and the H Series, with the convenience of metric dimensions and fasteners for your metric based designs. The W Series can be used in a wide range of applications from driving components with light torque requirements, such as encoders and tachometers (aluminum), to lead screws and pumps requiring greater torque (stainless steel).



## Attachment Methods

### Integral Clamp / WAC & W7C

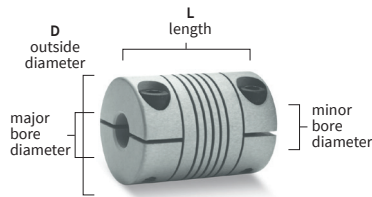

### Set Screw / WA & W7

(two each end @ 120°)

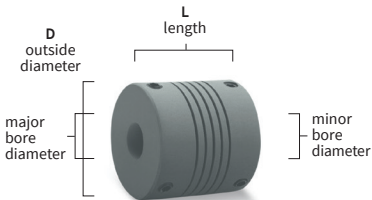

## Internal Configuration

### Relief \*

Major and minor diameter shafts may enter flexure area during operation

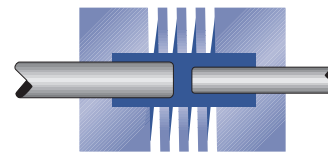

Unequal diameter shafts

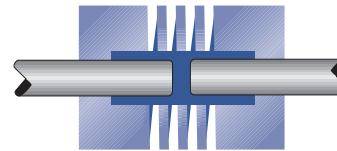

Equal diameter shafts

\* Dark areas indicate relief within the coupling interior

## How To Order

Coupling part numbers consist of four sections. To determine the correct numbers/letters for each section of a specific coupling part number, please refer to the charts on the following pages.

### Example

#### 01 Basic Model Number

(W = metric, A = aluminum, C = integral clamp)

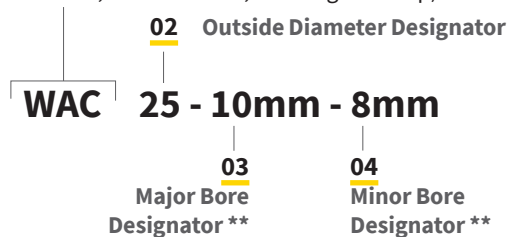

\*\* Refer to "Standard Bore Diameters" section of chart

#### 01 Basic Model Number:

Choose material and attachment method.

WAC = Aluminum, Integral Clamp

WA = Aluminum, Set Screw

W7C = Stainless Steel, Integral Clamp

W7 = Stainless Steel, Set Screw

**02 Outside Diameter Designator:** This two-digit number represents the coupling outside diameter. Based on the Performance Data in the middle of the chart, select the Outside Diameter Designator by moving left to the appropriate diameter.

**03 Major Bore Designator:** The larger of the two bores, its diameter is expressed in either millimeters (6mm) or in 32nds of an inch (-8 equals 1/4 inch). Please review your selection to determine if both bores can be made in the size coupling you have selected in **02**. It is important that the larger bore be stated first.

**04 Minor Bore Designator:** The smaller of the two bores is expressed the same as the Major Bore Designator. **Either bore can be mm or inch.** Please specify mm when metric.

## W Series, Aluminum, Technical Data

01		02		03 & 04		Attachment Screw							
Basic Model Number			Dimensional Information		Standard Bore Diameters		Performance Data		Inertia	Screw Size		Seating Torque	Center Line
Integral Clamp Attachment	Set Screw Attachment	Outside Diameter Designator	D Outside Diameter	L Length (mm)	(+0.05mm / -0.00mm) Note 5		Momentary Dynamic Torque Note 2 (Nm)	Torsional Rate (degree/Nm)	$\times 10^{-4}$ (kg cm sec <sup>2</sup> ) Note 6	Integral Clamp	Set Screw	(Nm)	(mm)
					Size (mm)	Bore Designator							
WAC	WA	15	15mm	22	3.00	3mm	0.71	5.1	0.028	M2x.4		0.5	2.5
				20	4.00	4mm	0.66	7.2	0.025				
WAC	WA	20	20mm	28	4.00	4mm	1.3	2.7	0.11	M3x.5		2.0	3.8
				20	5.00	5mm	1.2	3.5	0.079				
WAC	WA	25	25mm	30	6.00	6mm	2.9	1.5	0.30	M3x.5		2.0	3.8
				24	7.00	7mm	2.8	1.8					
WAC	WA	30	30mm	38	9.00	9mm	4.9	1.1	0.78	M4x.7		4.7	5.0
				30	10.00	10mm	4.6	1.3					
WAC	WA	40	40mm	50	12.00	12mm	12	0.45	3.3	M5x.8		9.5	5.8
				50	13.00	13mm	11	0.51					
WAC	WA	50	50mm	54	14.00	14mm	19	0.25	7.6	M6x1		16	6.7
				54	16.00	16mm	18	0.31					
					18.00	18mm	17	0.39					
					19.00	19mm	16	0.43					
					20.00	20mm	15	0.49					

### Notes

- Shaft misalignments:  
Angular 5 degrees  
Parallel Offset .25 mm  
(.50 mm T.I.R.)  
Axial Motion  $\pm$ .25 mm
- Dynamic torque ratings are momentary values. For non-reversing applications, divide by 2. Divide by 4 for reversing applications. Should the torque ratings be marginal for your application, contact us for analysis.

- Material: 7075-T6 aluminum alloy  
Finish: clear anodize  
or  
Material: 17-4 PH high-strength stainless steel.  
Finish: natural

- Manufacturing dimensional tolerances unless otherwise specified are:  
x  $\pm$ .5 mm  
x.x  $\pm$ .25 mm
- Refer to page 18 for other available bore diameters.
- Inertia is based on smallest standard bore diameter.
- Keyways available on the 40 mm and 50 mm OD only.

## W Series, Stainless Steel, Technical Data

01		02		03 & 04		Attachment Screw							
Basic Model Number			Dimensional Information		Standard Bore Diameters		Performance Data		Inertia	Screw Size		Seating Torque	Center Line
Integral Clamp Attachment	Set Screw Attachment	Outside Diameter Designator	D Outside Diameter	L Length (mm)	(+0.05mm / -0.00mm) Note 5		Momentary Dynamic Torque Note 2 (Nm)	Torsional Rate (degree/Nm)	$\times 10^{-4}$ (kg cm sec <sup>2</sup> ) Note 6	Integral Clamp	Set Screw	(Nm)	(mm)
					Size (mm)	Bore Designator							
W7C	W7	15	15mm	22	3.00	3mm	1.4	1.9	0.078	M2x.4		0.5	2.5
				20	4.00	4mm	1.3	2.6	0.070				
W7C	W7	20	20mm	28	4.00	4mm	2.6	0.99	0.32	M3x.5		2.0	3.8
				20	5.00	5mm	2.5	1.3	0.022				
W7C	W7	25	25mm	30	6.00	6mm	5.7	0.54	0.84	M3x.5		2.0	3.8
				24	7.00	7mm	5.5	0.66					
W7C	W7	30	30mm	38	9.00	9mm	9.5	0.40	2.2	M4x.7		4.7	5.0
				30	10.00	10mm	8.9	0.48					
W7C	W7	40	40mm	50	12.00	12mm	23	0.16	9.2	M5x.8		9.5	5.8
				50	13.00	13mm	22	0.19					
W7C	W7	50	50mm	54	14.00	14mm	37	0.092	21	M6x1		16	6.7
				54	16.00	16mm	35	0.11					
					18.00	18mm	33	0.14					
					19.00	19mm	31	0.16					
					20.00	20mm	30	0.18					

### Conversions

1mm = .039 inch

1Nm = 8.85 lb in

1deg/Nm = .113 deg/lb in

## Features

- High torsional stiffness
- Low radial loads
- Parallel misalignment capability
- Low inertia



DS SERIES

The DS Series was designed for today's high performance motion control systems. This Series incorporates two helical beams (double start) in each of two separate HELI-CAL Flexures (double flexure), combining greater end-to-end rotational accuracy with radial flexibility in one design.

Available only with integral clamp attachments, the DS Series provides the high torsional stiffness and low inertia necessary for positioning devices, servo motors and lead screws.

The DS Series also provides you with substantial .010-inch parallel offset capability, reducing the need for high-precision alignment during assembly operations. It's your ticket to greater system accuracy and reliability. Available only in 7075-T6 aluminum.

## Attachment Methods

### Integral Clamp / DSAC

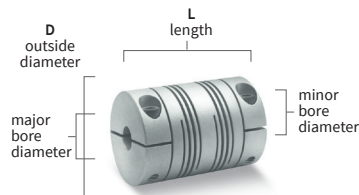

## Internal Configuration

### Relief \*

Major and minor diameter shafts may enter flexure area during operation

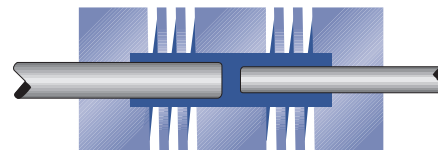

Unequal diameter shafts

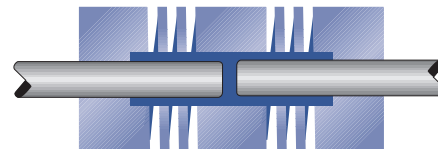

Equal diameter shafts

\* Dark areas indicate relief within the coupling interior

## How To Order

Coupling part numbers consist of four sections. To determine the correct numbers/letters for each section of a specific coupling part number, please refer to the charts on the following pages.

### Example

#### 01 Basic Model Number

(DS = double start, A = aluminum, C = integral clamp)

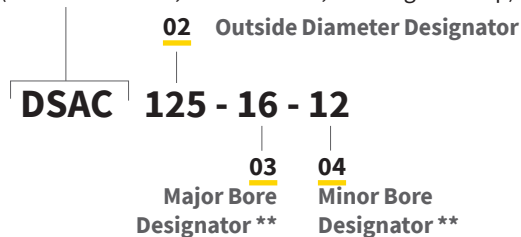

\*\* Refer to "Standard Bore Diameters" section of chart

#### 01 Basic Model Number:

DSAC = Double start flexure,  
Aluminum and Integral Clamp

**02 Outside Diameter Designator:** This three-digit number represents the coupling outside diameter. Based on the Performance Data in the middle of the chart, select the Outside Diameter Designator by moving left to the appropriate diameter.

**03 Major Bore Designator:** The larger of the two bores, its diameter is expressed in either 32nds of an inch (-8 equals 1/4 inch) or in millimeters (6mm). Please review your selection to determine if both bores can be made in the size coupling you have selected in **02**. **It is important that the larger bore be stated first.**

**04 Minor Bore Designator:** The smaller of the two bores is expressed the same as the Major Bore Designator. **Either bore can be inch or mm.**

## DS Series, Aluminum, Technical Data

01		02		03 & 04		Attachment Screw					
Basic Model Number		Dimensional Information		Standard Bore Diameters		Performance Data		Inertia	Screw Size	Seating Torque	Center Line
Integral Clamp Attachment	Outside Diameter Designator	D Outside Diameter in	L Length in	(+0.02in / -0.000in) Note 6 Size in & (mm)      Bore Designator (1/32 in)		Momentary Dynamic Torque Note 2 (lb in)	Torsional Rate (degree/lb in)	x 10 <sup>-4</sup> (lb in sec <sup>2</sup> ) Note 7	Integral Clamp Note 4	(lb in)	(in)
<b>DSAC</b>	<b>075</b>	¾	1.25	0.188 (4.78) 0.250 (6.35)	6 8	14 12	0.30 0.40	0.091	4-40	10	.12
<b>DSAC</b>	<b>100</b>	1	1.50	0.250 (6.35) 0.313 (7.95) 0.375 (9.53)	8 10 12	31 29 25	0.13 0.16 0.19	0.35	6-32	19	.15
<b>DSAC</b>	<b>125</b>	1 ¼	1.75	0.313 (7.95) 0.375 (9.53) 0.500 (12.70) 0.625 (15.88)	10 12 16* 20*	61 58 47 35	0.062 0.080 0.12 0.19	0.98	10-24	50	.22
<b>DSAC</b>	<b>150</b>	1 ½	2.25	0.375 (9.53) 0.500 (12.70) 0.625 (15.88)	12 16 20	130 115 94	0.030 0.042 0.062	2.7	10-24	50	.22
<b>DSAC</b>	<b>200</b>	2	2.50	0.500 (12.70) 0.625 (15.88) 0.750 (19.05)	16 20 24	234 215 190	0.016 0.020 0.026	9.5	¼-20	120	.26

Refer to note 8

### Notes

- |   |  |   |
|---|--|---|
| <p>01 Shaft misalignments:<br/>                     Angular            3 degrees<br/>                     Parallel Offset    .010 in (.020 in T.I.R.)<br/>                     Axial Motion      ± .008 in</p> <p>02 Dynamic torque ratings are momentary values. For non-reversing applications, divide by 2. Divide by 4 for reversing applications. Should the torque ratings be marginal for your application, contact us for analysis.</p> | <p>03 Material : 7075-T6 aluminum alloy<br/>                     Finish: clear anodize</p> <p>04 Metric fasteners available on request.</p> <p>05 Manufacturing dimensional tolerances unless otherwise specified are:<br/>                     fraction            ± 1/64<br/>                     x.xx                ± .01 in</p> | <p>06 Refer to page 18 for other available bore diameters.</p> <p>07 Inertia is based on smallest standard bore diameter.</p> <p>08 This bore size requires an operating clearance diameter greater than coupling outside diameter.</p> |
|---|--|---|



MC SERIES  
(aluminum shown)

## Features

- Industrial motor shaft couplings
- Large shaft diameters
- Large parallel misalignment capacity
- Keyways available
- High torque capacity

This versatile series of couplings provides you with a full range of torque capacities and bore sizes, all with 1/32-inch parallel misalignment capability. These couplings attach to shafts with your choice of integral clamps or set screws. Combine this with optional keyways and the MC Series is tailor-made for your application.

From medium-duty (aluminum) to heavy-duty (stainless steel), this series provides solutions for a wide range of applications. From pumps and lead screws to conveyors, chances are an MC Series coupling will fit your needs. Available in 7075-T6 aluminum alloy or 17-4 PH corrosion resistant steel (CRES).

## Attachment Methods

### Integral Clamp / MCAC & MC7C

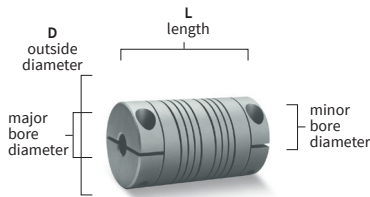

### Set Screw / MCA & MC7 (two each end @ 120°)

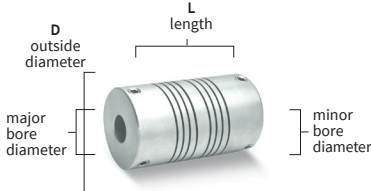

## Internal Configuration

### Relief \*

Major and minor diameter shafts may enter flexure area during operation

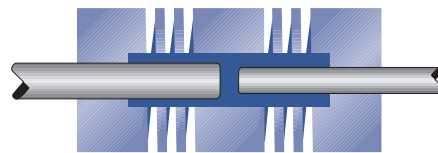

Unequal diameter shafts

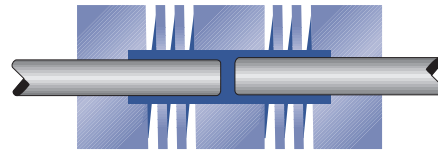

Equal diameter shafts

\* Dark areas indicate relief within the coupling interior

## How To Order

Coupling part numbers consist of four sections. To determine the correct numbers/letters for each section of a specific coupling part number, please refer to the charts on the following pages.

### Example

#### 01 Basic Model Number

(MC = motor coupling, A = aluminum, C = integral clamp)

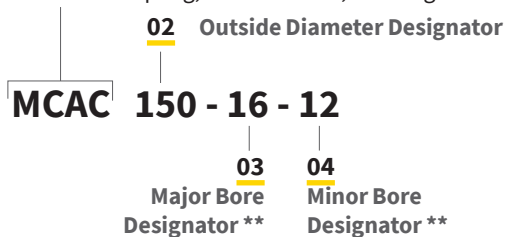

\*\* Refer to "Standard Bore Diameters" section of chart

#### 01 Basic Model Number:

Choose material and attachment method.

MCAC = Aluminum, Integral Clamp

MCA = Aluminum, Set Screw

MC7C = Stainless Steel, Integral Clamp

MC7 = Stainless Steel, Set Screw

**02 Outside Diameter Designator:** This three-digit number represents the coupling outside diameter. Based on the Performance Data in the middle of the chart, select the Outside Diameter Designator by moving left to the appropriate diameter.

**03 Major Bore Designator:** The larger of the two bores, its diameter is expressed in either 32nds of an inch (-8 equals 1/4 inch) or in millimeters (6mm). Please review your selection to determine if both bores can be made in the size coupling you have selected in **02**. It is important that the larger bore be stated first.

**04 Minor Bore Designator:** The smaller of the two bores is expressed the same as the Major Bore Designator. Either bore can be mm or inch.

## MC Series, Aluminum, Technical Data

01		02		03 & 04			Attachment Screw						
Basic Model Number			Dimensional Information		Standard Bore Diameters		Performance Data		Inertia	Screw Size		Seating Torque	Center Line
Integral Clamp Attachment	Set Screw Attachment	Outside Diameter Designator	D Outside Diameter (in)	L Length (in)	(+0.002in / -0.00in) Note 6 Size in & (mm)      Bore Designator (1/32 in)		Momentary Dynamic Torque Note 2 (lb in)	Torsional Rate (degree/lb in)	x 10 <sup>-4</sup> (lb in sec <sup>2</sup> ) Note 7	Integral Clamp Note 4	Set Screw Note 4	(lb in)	(in)
MCAC		100	1	1.75	0.250 (6.35)	8	26	0.270	0.41	6-32		19	.15
	MCA				0.313 (7.95)	10	23	0.370			10-24	25	.15
MCAC		125	1 1/4	2.37	0.313 (7.95)	10	51	0.130	1.3	10-24		50	.22
	MCA				0.375 (9.53)	12	47	0.170			1/4-20	65	.20
MCAC		150	1 1/2	2.62	0.375 (9.53)	12	100	0.065	3.1	10-24		50	.22
	MCA				0.500 (12.70)	16	88	0.100			1/4-20	65	.20
MCAC		200	2	3.00	0.500 (12.70)	16	178	0.035	11.4	1/4-20		120	.26
	MCA				0.625 (15.88)	20	164	0.049			1/4-20	65	.30
MCAC		225	2 1/4	3.50	0.625 (15.88)	20	286	0.024	21.5	1/4-20		120	.26
	MCA				0.750 (19.05)	24	262	0.032			1/4-20	65	.40
					0.875 (22.23)	28	233	0.044					

\*Refer to note 8

## MC Series, Stainless Steel, Technical Data

01		02		03 & 04			Attachment Screw						
Basic Model Number			Dimensional Information		Standard Bore Diameters		Performance Data		Inertia	Screw Size		Seating Torque	Center Line
Integral Clamp Attachment	Set Screw Attachment	Outside Diameter Designator	D Outside Diameter (in)	L Length (in)	(+0.002in / -0.00in) Note 6 Size in & (mm)      Bore Designator (1/32 in)		Momentary Dynamic Torque Note 2 (lb in)	Torsional Rate (degree/lb in)	x 10 <sup>-4</sup> (lb in sec <sup>2</sup> ) Note 7	Integral Clamp Note 4	Set Screw Note 4	(lb in)	(in)
MC7C		100	1	1.75	0.250 (6.35)	8	51	0.098	1.1	6-32		19	.15
	MC7				0.313 (7.95)	10	46	0.140			10-32	25	.15
MC7C		125	1 1/4	2.37	0.313 (7.95)	10	98	0.048	3.8	10-32		56	.22
	MC7				0.375 (9.53)	12	91	0.062			1/4-28	65	.20
MC7C		150	1 1/2	2.62	0.375 (9.53)	12	194	0.024	8.7	10-32		56	.22
	MC7				0.500 (12.70)	16	170	0.037			1/4-28	65	.20
MC7C		200	2	3.00	0.500 (12.70)	16	347	0.013	31.9	1/4-28		135	.26
	MC7				0.625 (15.88)	20	319	0.018			1/4-28	65	.30
MC7C		225	2 1/4	3.50	0.625 (15.88)	20	556	0.009	60.0	1/4-28		135	.26
	MC7				0.750 (19.05)	24	510	0.012			1/4-28	65	.40
					0.875 (22.23)	28	454	0.016					
					1.000 (25.40)	32	392	0.023					

\*Refer to note 8

## Notes

### 01 Shaft misalignments:

Angular 5 degrees  
Parallel Offset .030 in (.060 in T.I.R.)  
Axial Motion ±.010 in

02 Dynamic torque ratings are momentary values. For non-reversing applications, divide by 2. Divide by 4 for reversing applications. Should the torque ratings be marginal for your application, contact us for analysis.

03 Material : 7075-T6 aluminum alloy  
Finish: clear anodize  
**or**  
Material: 17-4 PH high-strength stainless steel.  
Finish: natural

04 Metric fasteners available on request.

05 Manufacturing dimensional tolerances unless otherwise specified are:  
fraction ± 1/64  
x.xx ± .01 in

06 Refer to page 19 for other available bore diameters.

07 Inertia is based on smallest standard bore diameter.

08 With integral clamp attachments only, this bore size requires an operating clearance diameter greater than coupling outside diameter.

09 Inch and metric keyways available.

# A Series, Aluminum and H Series, Stainless Steel



A SERIES

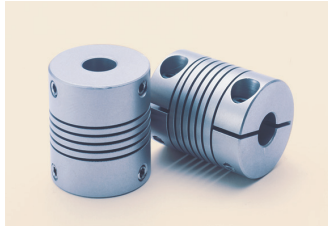

H SERIES

## Attachment Methods

### Integral Clamp / ACR & HCR

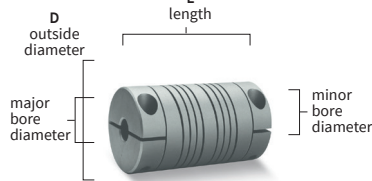

### Set Screw /AR & HR (two each end @ 120°)

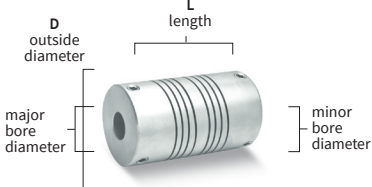

## How To Order

Coupling part numbers consist of four sections. To determine the correct numbers/letters for each section of a specific coupling part number, please refer to the charts on the following pages.

### Example

#### 01 Basic Model Number

(A = aluminum, C = integral clamp, R = internal relief)  
(H = Stainless Steel, C = integral claim, R = internal relief)

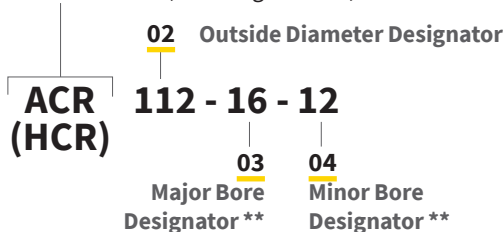

\*\* Refer to "Standard Bore Diameters" section of chart

## Features

### A Series

- Light to medium duty
- Non-magnetic
- Economical
- No maintenance

The A Series coupling meets performance demands over a wide range of applications, including drive systems for encoders, instrumentation, lead screws, small pumps, feed rollers and anywhere a light to medium duty, torsionally flexible coupling is required.

### H Series

- High torque capacity
- High fatigue resistance
- Corrosion resistant steel (CRES)

The H Series coupling is ideal when high strength, excellent fatigue resistance and high torsional stiffness is called for in your application. The H Series' premium performance capability is designed for applications requiring a heavy-duty coupling, such as drive systems, small pumps and gear boxes.

## Shared Features of the A & H Series

- No maintenance
- Shaft sizes from 3/32 to 3/4

An array of options, in a variety of diameter sizes, allows you to tailor the A or H Series to your specific applications. A and H Series options include set screw or integral clamp attachments and inch or metric bores.

## Internal Configuration

### Relief \*

Major and minor diameter shafts may enter flexure area during operation

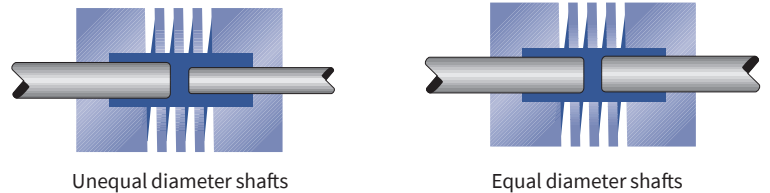

\* Dark areas indicate relief within the coupling interior

#### 01 Basic Model Number:

Choose material and attachment method.

ACR = Aluminum, Integral Clamp

AR = Aluminum, Set Screw

HCR = Stainless Steel, Integral Clamp

HR = Stainless Steel, Set Screw

**02 Outside Diameter Designator:** This three-digit number represents the coupling outside diameter. Based on the Performance Data in the middle of the chart, select the Outside Diameter Designator by moving left to the appropriate diameter.

**03 Major Bore Designator:** The larger of the two bores, its diameter is expressed in either 32nds of an inch (-8 equals 1/4 inch) or in millimeters (6mm). Please review your selection to determine if both bores can be made in the size coupling you have selected in **02**. **It is important that the larger bore be stated first.**

**04 Minor Bore Designator:** The smaller of the two bores is expressed the same as the Major Bore Designator. **Either bore can be mm or inch.**



## A Series, Aluminum, Technical Data

01			02		03 & 04			Attachment Screw					
Basic Model Number			Dimensional Information		Standard Bore Diameters		Performance Data		Inertia	Screw Size		Seating Torque	Center Line
Integral Clamp Attachment	Set Screw Attachment	Outside Diameter Designator	D Outside Diameter (in)	L Length (in)	(+0.02in / -0.00in) Note 6 Size in & (mm) Bore Designator (1/2 in)		Momentary Dynamic Torque Note 2 (lb in)	Torsional Rate (degree/lb in)	x 10 <sup>-5</sup> (lb in sec <sup>2</sup> ) Note 7	Integral Clamp Note 4	Set Screw Note 4	(lb in)	(in)
ACR	AR	050	1/2	0.75	0.094 (2.39)	3	3.7	0.98	0.11	1-72		4.0	.09
				0.50	0.125 (3.18)	4	3.5	1.3	0.069				
ACR	AR	062	5/8	0.80	0.125 (3.18)	4	7.1	0.51	0.28	2-56		4.5	.10
				0.62	0.157 (3.99)	5	6.7	0.66	0.21				
ACR	AR	075	3/4	0.90	0.125 (3.18)	4	10	0.29	0.66	4-40		10	.12
				0.75	0.157 (3.99)	5	10	0.36	0.54				
ACR	AR	087	7/8	1.06	0.188 (4.78)	6	19	0.20	1.5	6-32		19	.15
				0.87	0.250 (6.35)	8	17	0.28	1.2				
ACR	AR	100	1	1.25	0.250 (6.35)	8	27	0.17	3.0	6-32		19	.15
				1.00	0.313 (7.95)	10	24	0.24	2.3				
ACR	AR	112	1 1/8	1.50	0.250 (6.35)	8	43	0.094	5.6	6-32		19	.15
				1.12	0.313 (7.95)	10	40	0.12	4.1				
ACR	AR	125	1 1/4	1.62	0.375 (9.53)	12	48	0.11	9.3	10-24		50	.22
				1.25	0.500 (12.70)	16*	39	0.20	6.9				

\*Refer to note 8

## Notes

- Shaft misalignments:  
Angular 5 degrees  
Parallel  
Offset .010 in  
(.020 in T.I.R.)  
Axial Motion ±.010 in
- Dynamic torque ratings are momentary values. For non-reversing applications, divide by 2. Divide by 4 for reversing applications. Should the torque ratings be marginal for your application, contact us for analysis.

## H Series, Stainless Steel, Technical Data

01			02		03 & 04			Attachment Screw					
Basic Model Number			Dimensional Information		Standard Bore Diameters		Performance Data		Inertia	Screw Size		Seating Torque	Center Line
Integral Clamp Attachment	Set Screw Attachment	Outside Diameter Designator	D Outside Diameter (in)	L Length (in)	(+0.02in / -0.00in) Note 6 Size in & (mm) Bore Designator (1/2 in)		Momentary Dynamic Torque Note 2 (lb in)	Torsional Rate (degree/lb in)	x 10 <sup>-5</sup> (lb in sec <sup>2</sup> ) Note 7	Integral Clamp Note 4	Set Screw Note 4	(lb in)	(in)
HCR	HR	050	1/2	0.75	0.094 (2.39)	3	7.5	0.36	0.31	1-72		4.0	.09
				0.50	0.125 (3.18)	4	7.0	0.48	0.19				
HCR	HR	062	5/8	0.80	0.125 (3.18)	4	14	0.19	0.78	2-56		4.5	.10
				0.62	0.157 (3.99)	5	13	0.24	0.58				
HCR	HR	075	3/4	0.90	0.125 (3.18)	4	21	0.11	1.8	4-40		10	.12
				0.75	0.157 (3.99)	5	20	0.13	1.5				
HCR	HR	087	7/8	1.06	0.188 (4.78)	6	37	0.072	4.1	6-32		19	.15
				0.87	0.250 (6.35)	8	34	0.10	3.3				
HCR	HR	100	1	1.25	0.250 (6.35)	8	52	0.062	8.3	6-32		19	.15
				1.00	0.313 (7.95)	10	47	0.086	6.5				
HCR	HR	112	1 1/8	1.50	0.250 (6.35)	8	83	0.035	15.6	6-32		19	.15
				1.12	0.313 (7.95)	10	78	0.045	11.3				
HCR	HR	125	1 1/4	1.62	0.375 (9.53)	12	94	0.041	26.0	10-32		56	.22
				1.25	0.500 (12.70)	16*	77	0.071	19.4				

\*Refer to note 8

- Material: 7075-T6 aluminum alloy used for ACR / AR series. Finish: clear anodize or Material: 17-4 PH high-strength stainless steel used for HCR / HR series. Finish: natural
- Metric fasteners available on request.
- Manufacturing dimensional tolerances unless otherwise specified are:  
fraction ± 1/64  
x.xx ±.01 in
- Refer to page 19 for other available bore diameters.
- Inertia is based on smallest standard bore diameter.
- With integral clamp attachments only, this bore size requires an operating clearance diameter greater than coupling outside diameter.

## W Series | pages 10–11

Basic Model Number		Outside Diameter		Bore Diameters			
Integral Clamp Attachment	Set Screw Attachment	Outside Diameter Designator	D Outside Diameter	With Relief		Restricted Bore Configurations*	
				Minimum Size mm	Maximum Size mm	Maximum Size mm	Bore Depth mm
W7C-WAC		15	15mm	3.00	5.00	7.30	6.00
	W7/WA			3.00	5.00	9.00	4.85
W7C-WAC		20	20mm	4.00	6.35	9.81	8.55
	W7/WA			4.00	6.35	14.00	4.85
W7C-WAC		25	25mm	6.00	10.00	14.56	8.55
	W7/WA			6.00	10.00	17.00	5.85
W7C-WAC		30	30mm	9.00	12.70	17.30	11.00
	W7/WA			9.00	12.70	20.00	6.85
W7C-WAC		40	40mm	12.00	16.00	24.80	15.50
	W7/WA			12.00	16.00	25.40	17.00
W7C-WAC		50	50mm	14.00	20.00	32.11	15.50
	W7/WA			14.00	20.00	38.10	17.00

## DS Series | pages 12–13

Basic Model Number		Outside Diameter		Bore Diameters			
Integral Clamp Attachment	Outside Diameter Designator	D Outside Diameter (in)	With Relief		Restricted Bore Configurations*		
			Minimum Size in & (mm)	Maximum Size in & (mm)	Maximum Size in & (mm)	Bore Depth in & (mm)	
DSAC	075	¾	0.188 (4.78)	0.250 (6.35)	0.390 (9.90)	0.25 (6.35)	
DSAC	100	1	0.250 (6.35)	0.394 (10.00)	0.563 (14.31)	0.38 (9.65)	
DSAC	125	1 ¼	0.313 (7.95)	0.630 (16.00)	0.668 (16.98)	0.44 (11.18)	
DSAC	150	1 ½	0.375 (9.53)	0.630 (16.00)	0.908 (23.07)	0.57 (14.48)	
DSAC	200	2	0.500 (12.70)	0.750 (19.05)	1.280 (32.50)	0.68 (17.27)	

### Notes

- 01 Bore sizes are placed into the part number with leading dashes after the basic model number. Standard bore dimensions are noted in 32nds of an inch, such as 8/32 or 3/32. The respective dash numbers would be -8 and -3. Any bore dimensions that are not an integer number of 32nds should be converted to their millimeter equivalent with "mm" after the numerical designation, e.g., .315 in = 8 mm.
- 02 When specifying part numbers, metric bore diameters are specified without trailing zeros after the decimal point, e.g. .315 in = 8.00 mm, but the

bore designation is - 8mm. This is only for simplicity in ordering and does not affect the tolerances of the actual bore dimensions. Bore tolerances are specified on the *Engineering Proposal Form* at the end of the catalog.

- 03 Manufacturing dimensional tolerances unless otherwise specified are:

fract	x.xx	x.xxx	angle
± 1/64	±.010	±.005	±2°

x	x.x	x.xx	angle
±.5 mm	±.25mm	±.15mm	±2°

\* Restricted Bore Configuration

- 04 A complete line of specialty OEM and end-user products is available; please refer to the *Engineering Proposal Form* and/or contact our Engineering Department.
- 05 A chart showing our standard line of instrumentation couplings with precision bore tolerancing is available upon request.
- 06 All parts are available with metric or inch fasteners to be compatible with the fastener system used in your designs.
- 07 Bore diameters less than minimum listed may be possible for one bore only. Contact our Engineering Department.

Unequal diameter shafts

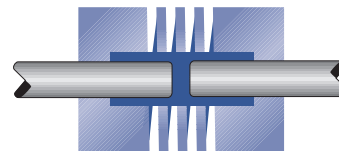
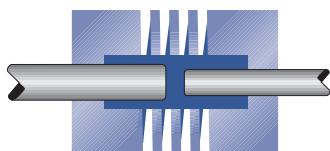

Equal diameter shafts

MC Series | pages 14–15

Basic Model Number				Outside Diameter		Bore Diameters			
Integral Clamp Attachment	Set Screw Attachment	Outside Diameter Designator	D Outside Diameter in	With Relief		Restricted Bore Configurations*			
				Minimum Size in & (mm)	Maximum Size in & (mm)	Maximum Size in & (mm)	Bore Depth in & (mm)		
MC7C			100	1	0.156 (3.96)	0.394 (10.00)	0.563 (14.30)	0.37 (9.40)	
	MCAC				0.156 (3.96)	0.394 (10.00)	0.563 (14.30)		
		MC7			0.156 (3.96)	0.394 (10.00)	0.630 (16.00)		
		MCA			0.156 (3.96)	0.394 (10.00)	0.630 (16.00)		
MC7C			125	1 ¼	0.313 (7.95)	0.630 (16.00)	0.668 (16.98)	0.51 (12.95)	
	MCAC				0.313 (7.95)	0.512 (13.00)	0.668 (16.98)		
		MC7			0.313 (7.95)	0.630 (16.00)	0.750 (19.05)		
		MCA			0.313 (7.95)	0.512 (13.00)	0.750 (19.05)		
MC7C			150	1 ½	0.313 (7.95)	0.630 (16.00)	0.908 (23.07)	0.66 (16.76)	
	MCAC				0.313 (7.95)	0.512 (13.00)	0.908 (23.07)		
		MC7			0.313 (7.95)	0.630 (16.00)	1.000 (25.40)		
		MCA			0.313 (7.95)	0.512 (13.00)	1.000 (25.40)		
MC7C			200	2	0.375 (9.53)	0.750 (19.05)	1.280 (32.50)	0.75 (19.05)	
	MCAC				0.375 (9.53)	0.630 (16.00)	1.280 (32.50)		
		MC7			0.375 (9.53)	0.750 (19.05)	1.500 (38.10)		
		MCA			0.375 (9.53)	0.630 (16.00)	1.500 (38.10)		
MC7C			225	2 ¼	0.375 (9.53)	1.000 (25.40)	1.525 (38.73)	0.86 (21.84)	
	MCAC				0.375 (9.53)	0.875 (22.23)	1.525 (38.73)		
		MC7			0.375 (9.53)	1.000 (25.40)	1.750 (44.45)		
		MCA			0.375 (9.53)	0.875 (22.23)	1.750 (44.45)		

A and H Series | pages 16–17

Basic Model Number		Outside Diameter		Bore Diameters			
Integral Clamp Attachment	Set Screw Attachment	Outside Diameter Designator	D Outside Diameter in	With Relief		Restricted Bore Configurations*	
				Minimum Size in & (mm)	Maximum Size in & (mm)	Maximum Size in & (mm)	Bore Depth in & (mm)
ACR/HCR		050	½	0.090 (2.29)	0.125 (3.18)	0.236 (6.00)	0.19 (4.83)
	AR/HR			0.090 (2.29)	0.125 (3.18)	0.315 (8.00)	0.12 (3.05)
ACR/HCR		062	⅝	0.090 (2.29)	0.197 (5.00)	0.325 (8.26)	0.20 (5.08)
	AR/HR			0.090 (2.29)	0.197 (5.00)	0.375 (9.53)	0.14 (3.56)
ACR/HCR		075	¾	0.118 (3.00)	0.250 (6.35)	0.390 (9.90)	0.25 (6.35)
	AR/HR			0.118 (3.00)	0.250 (6.35)	0.512 (13.00)	0.18 (4.57)
ACR/HCR		087	⅞	0.138 (3.50)	0.315 (8.00)	0.444 (11.27)	0.31 (7.87)
	AR/HR			0.118 (3.00)	0.315 (8.00)	0.630 (16.00)	0.20 (5.08)
ACR/HCR		100	1	0.156 (3.96)	0.375 (9.53)	0.563 (14.31)	0.31 (7.87)
	AR/HR			0.156 (3.96)	0.375 (9.53)	0.630 (16.00)	0.26 (6.60)
ACR/HCR		112	1 ⅛	0.188 (4.78)	0.512 (13.00)	0.684 (17.38)	0.45 (11.43)
	AR/HR			0.188 (4.78)	0.512 (13.00)	0.630 (16.00)	0.27 (6.86)
ACR/HCR		125	1 ¼	0.313 (7.94)	0.625 (15.88)	0.669 (17.00)	0.51 (12.95)
	AR/HR			0.313 (7.94)	0.625 (15.88)	0.750 (19.05)	0.32 (8.13)

## Features

- Ideal for motion control applications (servo motors).
- Up to 10 times greater torsional stiffness than beam types.
- Low-cost alternative to bellows types.
- No moving parts.
- No maintenance.
- No backlash.
- No lubrication.
- Excellent quality.

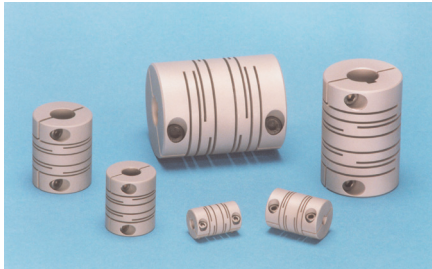

X SERIES

The X-series couplings offer a cost-effective balance between couplings that are too stiff radially and those not stiff enough torsionally for servo-type applications. It features high torsional stiffness, low radial loads, one-piece integrity, good flexibility, and zero backlash. Created for high-performance motion control systems, the X-Series incorporates two flexible element sets—combining greater end-to-end rotational accuracy with radial flexibility—in one design.

### X-Series, Aluminum, Technical Data

Bore Diameter +.05 / -.00 mm		Performance Data			Basic Model Number	Dimensional Information		Inertia †	Attachment Metric Cap Screws		Weight
Min (mm)	Max (mm)	Torque Rating (Nm)	Torsional Rate (Deg/Nm)	Parallel Offset (mm)		OD (mm)	L (mm)	X 10 <sup>-4</sup> (kg cm sec <sup>2</sup> )	Size (mm)	Seating Torque (Nm)	Weight (grams)
3.00	6.00	0.30	1.13	0.10	<b>XCA15</b>	15*	24	0.028	M2.50 -.45	1.1	9.2
4.00	8.00	0.50	0.46	0.10	<b>XCA20</b>	20**	28	0.11	M3 -.5	2.0	20
6.00	10.00	1.00	0.22	0.15	<b>XCA25</b>	25	30	0.30	M3 -.5	2.0	33
9.00	12.70	2.00	0.13	0.15	<b>XCA30</b>	30	38	0.78	M4 -.7	4.7	60
10.00	17.00	5.00	.066	0.20	<b>XCA40</b>	40	60	3.9	M5 -.8	9.5	177
12.00	22.23	10.00	.029	0.20	<b>XCA50</b>	50	65	10.5	M6 -1.0	16	306

Angular: 3 degrees Axial: +/- .25mm Max. RPM: 10,000  
Keyways available upon request with XCA40 and XCA50

\* Clearance diameter for cap screw = 17.5mm

\*\* Clearance diameter for cap screw with bores over 6.35mm = 21.8mm

† Inertia is based on smallest standard bore

## How To Order

### Example

#### Basic Model Number

(X = cross-slotted coupling, C = integral clamp, A = aluminum)

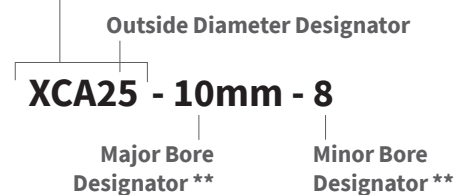

Metric bores are specified as millimeter size (-10mm).

Inch bores are expressed as number of 32nds (-8 = 8/32 = 1/4" = .250").

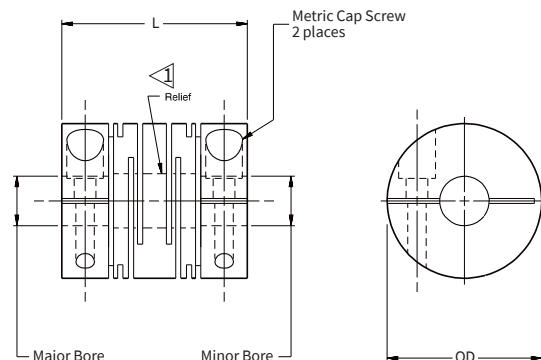

1 Major and minor diameter shafts may enter flexing area during operation.

# Idea Stimulators, Universal Joints

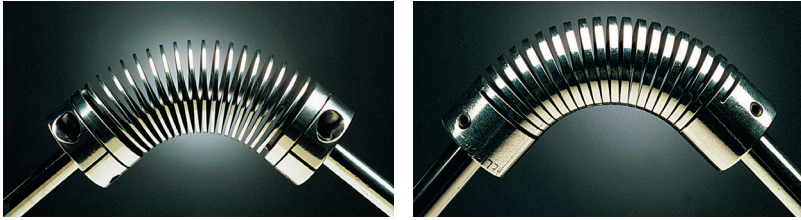

Helical flexured u-joints can be made to suit specific specifications and/or requirements. Note coil widths.

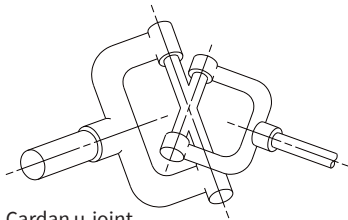

Cardan u-joint

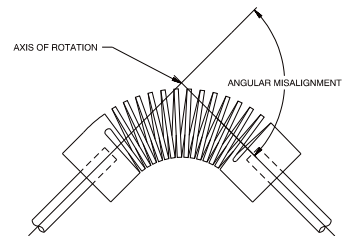

HELI-CAL Flexure

## A New Angle on Universal Joints

### HELI-CAL Flexured U-joints Provide Precision Operating Characteristics

A universal joint is a mechanical connection between rotating shafts which are generally not in parallel, but intersecting. “U-joints” transmit torque and motion.

U-joints are used in a variety of applications, wherever handling significant angular misalignment is the main focus. Typical applications include: articulating mechanisms, food processing equipment, replacement for expensive gearboxes, and

drives where motor position must be moved angularly off centerline of the driven unit.

The oldest and most common type of u-joint is called the Cardan or Hooke type joint. It consists of hub yokes, connected by a cross-shaped intermediate member. These popular u-joints are frequently used in automotive applications. Because the design incorporates several different piece parts, the moving parts of this type of u-joint usually require lubrication; and as the joint wears, the amount of backlash or free play within the joint itself grows. Even a lubricated Cardan u-joint will require periodic maintenance, and may leak lubricant.

Performance-wise, Cardan u-joints can transmit relatively high torque with minimal radial loads. But, by design, these u-joints have difficulty compensating for parallel offset and axial misalignment. Cardan types also introduce rotational inconsistencies into drive systems, a phenomenon known as “non-constant velocity rotation.”

The HELI-CAL Flexure is an advanced and unique u-joint solution that generally exceeds the capabilities of common u-joint designs. The u-joint is really a flexure capable of over 5° of angular misalignment. It may accommodate up to 90° of angular misalignment in certain circumstances. This type of u-joint will also compensate for axial and parallel misalignment.

A frequent application of the flexured u-joint is the direct replacement for a 90° bevel gearbox. Gearboxes are expensive, and usually need lubrication for their meshing gear surfaces and bearings. Replacement with a maintenance free Helical flexured u-joint can save money, both on initial purchase price and on maintenance costs. Flexured u-joints can be beneficial most anywhere—for example: aerospace, appliances, electronics, control mechanisms and drives, medical and optical devices, sewing machines, instrumentation, and textile machinery.

The performance capability of each HELI-CAL Flexure is determined by characteristics such as: flexure outside diameter, inside diameter, coil thickness, material, number of coils, and number of starts. By altering these characteristics, torque capacity, angular and parallel misalignment capabilities, torsional and lateral bending rates of flexured u-joints can be made to suit specific specifications and/or requirements.

### By using a flexured u-joint, the customer benefits from:

- Choice of materials
- Unlimited choice of end attachments
- Optimized misalignment and torque capacities
- A variety of torsional and lateral bending rates
- Ability to run in either manual or motor-driven applications
- Constant velocity

### An added bonus—flexured u-joints do not have:

- Backlash
- Moving parts
- Maintenance and lubrication requirements
- Limited selection of capabilities and sizes
- Limited angular misalignment capability

Once the designer/customer provides Helical with the performance requirements for his/her device, machine, or equipment, a specific flexure design that will meet or exceed application requirements is developed. An attachment may also be specified to securely interface with adjacent components. The result is a Helical flexured u-joint that works as an integral part of the customer’s application.

Flexured u-joints are tailor-made for customer applications, using customers’ specific requirements as a starting point. The finished product is a Helical flexured u-joint that “fits like a glove” in the device, machine, or equipment.

Helical Products, with its unique HELI-CAL Flexure, covers most u-joint requirements. Whether the application requires just a small angle of slightly more than 5°, or one calling for a 90° bend, Helical Products has a “flexure” answer. This “answer” employs the infinitely variable HELI-CAL Flexure, with its extensive range of variable characteristics. No longer is it necessary to use a “one size fits all” approach to u-joints.

## Flexure Attachments That Make Sense

### How To Make The Right Connections

For many years Helical Products has been recognized as the pioneer in the design and manufacture of helical beam-type couplings, universal joints (UJs) and machined springs. The unique capabilities of the HELI-CAL Flexure have solved countless design projects for engineers in many industries.

But curiously, engineers or designers often overlook how important the integration of the attachments is for improving component performance. Typically, the portion of a coupling that fastens, clamps, meshes or otherwise contacts adjacent components is referred to as an “attachment.” It is these various attachments and their potential impact on system design, we will discuss here.

First, let’s consider some of the special characteristics inherent to a HELI-CAL Flexure. Flexured couplings and UJs are backlash-free and provide constant velocity rotation regardless of misalignment. Any means of attachment used in conjunction with this type of product should maintain these properties, and complement them.

The key to assuring this attachment method does not compromise the effectiveness of the entire system is knowing the configuration of the adjacent components, D-shafts for example, and the anticipated duty cycle the component will encounter.

Clamp-style attachments are frequently used as a zero backlash, positive means of transmitting rotational motion between components. When compared to set screws on a performance basis, clamps squeeze around the shaft circumference rather than creating a dimple in the shaft. Clamp attachments better lend themselves to applications where the components are assembled and disassembled occasionally. Clamps require more linear space for the coupling, are inherently less dynamically balanced and slightly more expensive to manufacture. At times neither



The right attachment will reduce assembly/production costs.

of these attachment methods may be optimal for your application. This raises the question,

### “What other alternatives do I have?”

The variety of attachments available is limited only by the imagination of the design engineer, and the laws of physics. The configuration of coupling attachments can be as simple as the plain bore or as complex as a pinion gear. The purpose of seeking a customized attachment is to minimize the cost, optimize performance, simplify design, reduce system size, or reduce weight.

By using the HELI-CAL Flexure along with an attachment, the engineers have versatility in their system design. Most designers view a special or modified standard with a cost being too great. In actuality, customized attachments more than pay for themselves. The proper attachment will minimize assembly-production time and reduce the total number of parts to purchase, to maintain in inventory, and to assemble. All of this produces an overall production savings.

Pictured are some examples of customized attachments and the benefits they have provided.



A threaded shaft attachment offers several advantages. Fine axial length adjustments and blind assembly are just two potential uses.

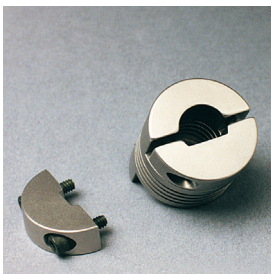

Detachable caps permit flexure installation where components cannot be spread apart to slide the flexure onto component shafts.



Integrating a lever arm into a clamp attachment flexure allowed linear motion to be converted to rotary motion.



A custom blind attachment designed to transmit torque in a single direction.

# Idea Stimulators, Machined Springs



## Machined Springs

### Q: What is a machined spring?

A: A machined spring is a single piece of material machined into a spring configuration. Key to the versatility of the machined spring is the HELI-CAL Flexure, a flexible helix beam concept utilized in the manufacture of Helical machined springs. Because Helical springs are “machined” to specific design requirements, they provide more precise performance, features and functions than can other more traditional types of springs.

### Q: What are some of the advantages of machined springs over conventional springs?

A: With machined springs, desired features or functions can be made part of the spring, such as: special attachments, precise spring rates, multiple integral coils, and other special characteristics. These aspects are generally not possible with traditional springs.

Machined springs also support multiple design objectives such as reliability, repeatability, and integration of multiple parts, which results in a reduction of assembly complexity.

### Single start spring

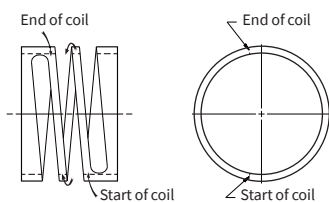

### Double start spring

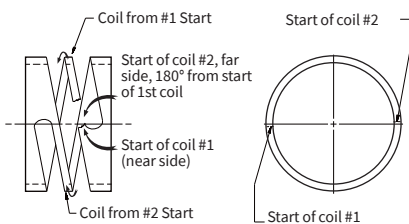

### Q: How are machined springs different?

A: The ends of machined springs can be made very square, a beneficial feature for compression springs. Attachments for torsional springs can be integrated so that no forces act upon the spring, just the moment enabling torsional deflections. Extension (tension) springs can include robust attachments that are resistant to breakage. Machined springs can provide very precise, linear deflection rates because virtually all residual stresses are eliminated. As a result, there are no internal stresses to overcome before deflection occurs.

### Q: Explain the terms “single start” and “multiple starts.”

A: A **Single Start Spring** is a single continuous coil element which starts at one end and terminates at the other end. This configuration is common to most springs.

A **Double Start Spring** has two intertwined continuous coil elements. In effect, this puts two independent helices in the same cylindrical plane. Multiple start flexures, such as triple start, etc., are similar extensions of the concept.

### Q: What are some of the benefits of multiple start flexures?

A: Multiple start flexures are beneficial because they not only provide redundant elastic elements should a failure occur, but a failed element (coil) will be physically trapped by the remaining one(s).

Another multi-start benefit applies to compression and tension springs. When compressed (or extend-ed), single start springs provide a reaction force plus a moment. This moment is created because the line of action is through the longitudinal centerline of the spring, and the spring force is action at the coil mean centerline. The distance between these centerlines provides the moment arm of the subject moment. On multiple start flexures, all internal moments are resolved within the spring. The big benefit is that these multiple start springs then compress (or extend) in a very straight manner. There is no tendency for the spring to bend laterally when deflected, and no restraint is necessary to resolve the free moment.

Sometimes there is a desire to have multiple elastic rates in machined spring. For instance, a compression torsion and lateral bending rate may be specified. With most types of springs accomplishing one of these rates can be a challenge, but three is impossible. Not so with a multiple start Helical machined spring. A machined spring designer can choose coil size, number of coils and multiple start coil features to achieve specified, different, elastic rates.

### Q: I understand that machined springs can be designed so that the coils don't touch. Does this mean that no sound would be generated by the spring?

A: Exactly. In those applications where resonance is desired for high efficiencies, the best choice is a machined spring of a multiple start configuration. In fact, machined springs may be the only choice under these circumstances. The linear rate and non-contact feature of the machined spring provide outstanding performance. The multiple start aspect prevents lateral bending and lateral translations from compromising in-line motions.

# Engineering Proposal Form



Proposal Form for Couplings and U-Joints (Please refer to the literature request form for machined spring proposal forms.)

Name \_\_\_\_\_ Telephone \_\_\_\_\_ E-Mail \_\_\_\_\_  
 Company \_\_\_\_\_ Fax \_\_\_\_\_  
 Address \_\_\_\_\_  
 Street / P.O. Box \_\_\_\_\_ City \_\_\_\_\_ State \_\_\_\_\_ Zip \_\_\_\_\_

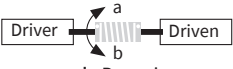
## Operating Information

**01 Drive \***  
 a. or b. Direction   
 c. Continuous \_\_\_\_\_  
 d. Reversing \_\_\_\_\_  
 e. Stop-Start \_\_\_\_\_ cycles/sec  
 f. RPM \_\_\_\_\_ g. Manual \_\_\_\_\_

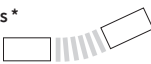
**02 Service \***  
 a. Operating Torque \_\_\_\_\_ lb in or Nm  
 b. Maximum Torque \_\_\_\_\_ lb in or Nm

**03 Misalignments \***  
 a. Angular  \_\_\_\_\_ deg  
 b. Parallel  \_\_\_\_\_ in or mm  
 c. Axial Compression/Extension \_\_\_\_\_ in or mm  
 d. Skew - please provide sketch \_\_\_\_\_

**04 Torsional Rate \***  
 \_\_\_\_\_ deg/lb in or deg/Nm  
 a. less than \_\_\_\_\_ b. equal to \_\_\_\_\_ c. greater than \_\_\_\_\_

**05 Inertial Limitation / Mass Moment of Inertia**  
 \_\_\_\_\_ lb in sec<sup>2</sup> or Kg cm sec<sup>2</sup>  
 a. less than \_\_\_\_\_ b. equal to \_\_\_\_\_ c. greater than \_\_\_\_\_

**06 Weight**  
 \_\_\_\_\_ oz. or gm.  
 a. less than \_\_\_\_\_ b. equal to \_\_\_\_\_ c. greater than \_\_\_\_\_

**07 Environment**  
 a. Temperature \_\_\_\_\_ °F or °C  
 b. Corrosive \_\_\_\_\_  
 c. Abrasive \_\_\_\_\_

## Flexure and Component Layout

**08 a.\* Preferred Outside Diameter** \_\_\_\_\_ in or mm  
 Maximum Outside Diameter \_\_\_\_\_ in or mm  
**b.\* Preferred Length** \_\_\_\_\_ in or mm  
 Maximum Length \_\_\_\_\_ in or mm

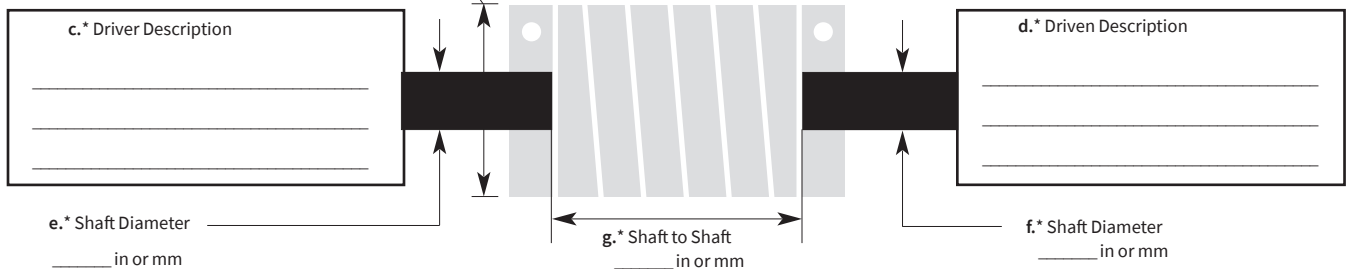

**09 Bore Tolerance**  
 a. Commercial  
 +.002 in -.000 in  
 or  
 +.05 mm -.00 mm  
 b. Precision  
 +.0005 in -.0000 in  
 or  
 +.015 mm -.000 mm

ATTACHMENTS		
10 Driver*		11 Driven*
a	Integral Clamp	a
b	2 Set Screws at 120°	b
c	2 Set Screws at 90°	c
d	1 Set Screw	d
e	Roll Pin ___ in or mm	e
f	Dowel Pin ___ in or mm	f
g	Keyway type _____ size _____	g
h	Other / Describe Below	h

**12 Material**  
 \_\_\_\_\_ 7075-T6 Aluminum Alloy  
 \_\_\_\_\_ 17-4 PH Stainless Steel  
 \_\_\_\_\_ Other \_\_\_\_\_

**13 Production Quantity**  
 \_\_\_\_\_ 1-24  
 \_\_\_\_\_ 25-100  
 \_\_\_\_\_ 100+

\*Items marked with an asterisk are essential for optimum design.

Type of Equipment \_\_\_\_\_

Comments \_\_\_\_\_



# Top Industries Served



Military Aviation



Medical



Space

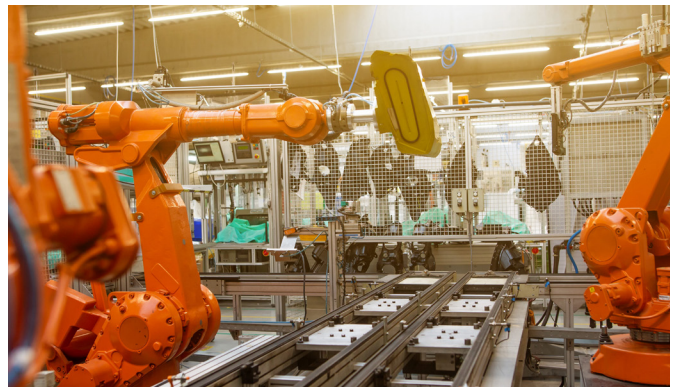

Automation



Commercial Aviation



Energy

## Helical Products

At **Helical Products** our U.S. manufacturing and catalog distribution facility represents the most diverse and inclusive supply base for a tremendous range of applications in numerous industries, including the aerospace, medical, energy, automation, and consumer markets—to name a few. Our range of products and sizes, our commitment to innovation within each industry and product category, and our superior engineering expertise further strengthens our position as an industry leader and world-class supplier for all markets. We have the resources within our broader organization (MW Components) to meet all your needs, regardless of the industry. Visit [heli-cal.com](http://heli-cal.com) to learn more.

“Man’s mind, once stretched by a new idea,  
never regains its original dimensions.”

- Oliver Wendell Holmes

## **Helical Products**

### Helical Products

AS9100/ISO 9001 Certified, RoHS & ITAR Compliant

901 W. McCoy Lane, P.O. Box 1069, Santa Maria, CA 93456

Phone 805.928.3851 | Fax 805.928.2369

[heli-cal.com](http://heli-cal.com)

©Copyright 2022, MW Components



Made in USA